

RA890G Protectorelay™ Primary Control

The RA890G Protectorelay™ control provides solid state electronic safeguard protection for industrial and commercial gas, oil, or combination gas-oil burners.



- Designed for interrupted ignition with intermittent pilot for gas burners, and for interrupted or intermittent ignition on oil burners.
- Used only with a C7027, C7035, or C7044 Mini-peeper Ultraviolet Flame Detector.
- Either a line voltage or low voltage controller can be used.
- Solid state circuitry eliminates warmup and increases resistance to vibration.
- Push-to-reset safety switch button is in dust-resistant enclosure.
- Safe start check prevents start if flame or flame simulating failure is present.
- Automatic safety switch lockout if flame fails on start or if flame is not re-established after a flame failure.
- When limit control opens, control de-energizes ignition and fuel valves, but safety switch lockout will not occur.
- Test jack permits readings of flame signal.
- Easy mounting and removal through use of captive mounting screws. Durable thermosplastic mounting base.
- -40°F (-40°C) approved model available.

CONTENTS

<i>Specifications</i>	2
<i>Ordering Information</i>	2
<i>Installation</i>	3
<i>Operation And Checkout</i>	5
<i>Service</i>	8
<i>Troubleshooting</i>	9



Specifications

TRADELINE® MODELS

TRADELINE® models are selected and packaged to provide ease of stocking, ease of handling, and maximum replacement value. TRADELINE® model specifications are the same for standard models except as noted below.
TRADELINE® MODELS AVAILABLE: RA890G Protectorelay™ Primary Control—120 Vac, 50/60 Hz.

STANDARD MODELS

MODEL: RA890G Protectorelay™ Primary Control.
VOLTAGE AND FREQUENCY: 120V, 208V, 220V, 240V; 50/60 Hz models.
VOLT-AMPERE RATING:
 60 Hz: 14 VA maximum, 12 VA standby.
 50 Hz: 18 VA maximum, 17 VA standby.
POWER CONSUMPTION:
 60 Hz: 9.5W maximum, 3W standby.
 50 Hz: 10W maximum, 4W standby.
FLAME FAILURE RESPONSE TIME: 0.8 or 3 seconds (nominal; separate models). 3 second response time recommended for nonrecycling cutoff system.
FLAME ESTABLISHING PERIOD: Up to 15 seconds (nominal).
RECYCLE TIME: Occurs immediately when flame loss is recognized. See Flame Failure Response Time.
SAFETY SWITCH TIMING (LOCKOUT TIMING): 15 seconds. Timings are proportional with input voltages and temperatures. For RA890 classified in Underwriters Laboratories Inc gas groups 6 and 6a and oil group 8, the maximum safety switch timing with voltages ranging from 70 to 110 percent of rated voltage and with ambients ranging from 32°F (0°C) to 115°F (66°C) are allowed to be as high as 50 seconds.
DIMENSIONS (Including Subbase): Approximately 5 x 5 x 5 (127 x 127 x 122 mm).
AMBIENT TEMPERATURE RATING:
MINIMUM: Models with 15 second safety switch: -20°F (-29°C).

MAXIMUM: Models without alarm contacts:
 50 Hz: 115°F, 46°C.
 60 Hz: 125°F, 52°C.
 Models with alarm contacts:
 50 Hz: 105°F, 41°C.
 60 Hz: 115°F, 46°C.

ALARM CONTACTS (Optional): Isolated spdt contacts. Alarm terminals are male quick-connects (female quick-connects included for field installation). See rating above.
FLAME DETECTOR: C7027, C7035 or C7044 Ultraviolet Flame Detector.

MOUNTING: Q270A Universal Mounting Base (ordered separately).

ELECTRICAL RATINGS:

Terminal	Electrical Load		120 Vac	240 Vac
			3	Burner Motor
	Locked Rotor	31.2A	15.6A	
	Ignition ^a	3.0A	1.5A	
	Pilot Fuel Valve	25VA	25VA	
4	Ignition ^a		3.0A	1.5A
5	Main Valve (Pilot Duty)		125VA	125VA
	Alternate Rating: 25 VA pilot duty plus one or more motorized valves with total rating of 400 VA opening, 200 VA holding.			

^a If ignition and motor are connected to terminal 3, terminal 4 cannot be used. This prevents overloading relay 1K.

Alarm Contacts: 3.0 A at 24 Vac, or 75 VA pilot duty at 120 Vac in suitable wiring enclosure.
 Low Voltage Control Circuit (T-T): 0.17A.

NOTE: Allowable inrush can be up to ten times the pilot duty rating.

Ordering Information

When purchasing replacement and modernization products from your TRADELINE® wholesaler or distributor, refer to the Tradeline Catalog or price sheets for complete ordering number, or specify—

1. Order number specify TRADELINE®, if desired.
2. Voltage and frequency.
3. Flame response time.
4. Alarm contacts, if desired.
5. Accessories, if desired.

If you have additional questions, need further information, or would like to comment on our products or services, please write or phone:

1. Your local Home and Building Control Sales Office (please check the white pages of your phone directory).
2. Home and Building Control Customer Logistics
 Honeywell Inc., 1885 Douglas Drive North
 Minneapolis, Minnesota 55422-4386 (612) 951-1000

In Canada—Honeywell Limited/Honeywell Limitée, 740 Ellesmere Road, Scarborough, Ontario M1P2V9. International Sales and Service Offices in all principal cities of the world. Manufacturing in Australia, Canada, Finland, France, Germany, Japan, Mexico, Netherlands, Spain, Taiwan, United Kingdom, U.S.A.

EXAMPLE: Pilot duty rating = 25 VA.
At 120V, running current is $25 \div 20 = 0.21A$.
Maximum allowable inrush is 10 times 0.21 = 2.1A.

UNDERWRITERS LABORATORIES INCLISTED: 120V models only: File no. MP268, Guide no. MCCZ.

NOTE: All devices meeting UL component recognition bear the following symbol: 

Canadian Standards Associated Certified: 120 V models only: File no. LR9S329
Factory Mutual Approved: Report no. 22013.

American Gas Association Design Certified For -20°F (-29°C). Certificate no. 20-6b.

ACCESSORIES:

- Models with 15 second safety switch: -20F (-29°C).
- W136A Microammeter.
- 123514B Flame Simulator.
- 196146 Meter Connector Plug.
- FSP1535 Test Panel: For operational check of the RA890E,F,G,H,J or the R4795.
- 118702E Remote Reset Cover Assembly.
- 202471A Cover Assembly with reset button.

Installation

CAUTION

Ultraviolet sensing tubes have a life expectancy of 40,000 hours of continuous use within the ambient temperature and voltage ratings. Worn out ultraviolet sensing tubes result in failure of the sensing tube to properly discriminate between flame conditions.

Systems using the RA890G with the C7027, C7035 and C7044 Flame Detectors should only be used on burners that cycle On and Off at least once every 24 hours. Appliances with burners that remain on for 24 hours continuously or longer should use the C7012E Flame Detector with the R7247C Amplifier or the C7076A Flame Detector with the R7476A Amplifier as the ultraviolet flame detection system.

WHEN INSTALLING THIS PRODUCT...

1. Read these instructions carefully. Failure to follow them could damage the product or cause a hazardous condition.
2. Check the ratings given in the instructions and on the product to make sure the product is suitable for your application.
3. Installer must be a trained, experienced flame safeguard control technician.
4. After installation is complete, check out product operation as provided in these instructions.

CAUTION

1. Disconnect power supply before beginning installation to prevent electrical shock and equipment damage. All wiring must comply with applicable local electrical codes, ordinances, and regulations.
2. Limits must be rated to carry and break current to the ignition transformer, pilot valve (or first stage oil valve), and main fuel valve(s) simultaneously.
3. All external timers must be Listed or Component Recognized by authorities that have jurisdiction for the specific purposes for which they are used.

Follow the burner manufacturer instructions when supplied; otherwise, proceed as follows.

LOCATION

Temperature

Install the RA890G where the surrounding temperatures remain within the ambient Operating Temperature Ratings listed in the SPECIFICATIONS section.

Humidity

Install the RA890G where the relative humidity never reaches the saturation point. Condensation of moisture on the RA890G may cause enough leakage to short the flame signal to ground and prevent the burner from starting.

Vibration

Do not install the RA890G where it could be subject to excessive vibration. Vibration shortens the life of the electronic components.

Weather

The RA890G is not designed to be weathertight. If it is installed outdoors, use a suitable weathertight enclosure.

MOUNT SUBBASE

Locate subbase where ambient temperature is within the specified rating.

Mount the subbase so that the top and bottom are horizontal and the back is vertical. The subbase may lean backward as much as 45 degrees if necessary. See Fig. 1.

Fig. 1—Mounting Subbase. in in. (mm)

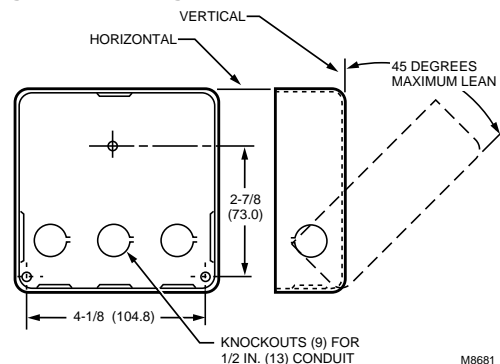

WIRING THE SUBBASE

IMPORTANT: When connecting wire to screw terminal of terminal strip, wrap wire at least 3/4 of distance around screw without overlapping. With appropriately sized screwdriver, tighten screw until wire is snugly in contact with underside of screw and contact plate. Tighten screw additional one-half turn. Do not use push-type ratchet screwdriver.

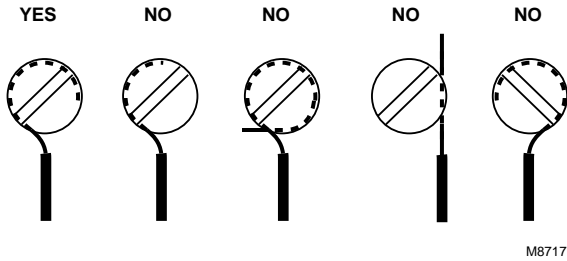

1. All wiring must comply with applicable electrical codes, ordinances, and regulations. Use NEC Class 1 wiring.
2. For *normal installations*, use moisture-resistant No. 14 wire (rated for 167°F (75°C) or higher required by Underwriters Laboratories Inc).
3. For *high temperature installations*, use moisture-resistant No. 14 wire selected for a temperature rating above the maximum operating temperature for all but the ignition and flame detector F leadwires.

- a. For *the ignition*, use Honeywell Specification no. R1061012 Ignition Cable or equivalent. (This wire is rated at 350°F (175°C) for continuous duty, and up to 500°F (260°C) for intermittent use. It was tested to 25,000 volts.)
- b. For *the flame detector F leadwire*, use Honeywell Specification no. R1298020 or equivalent. (This wire is rated up to 400°F (205°C) for continuous duty. It is tested for operation up to 600 volts and breakdown up to 7500 volts.)

4. For *ignition installations in a contaminating environment*, use Honeywell Specification no. R1239001 High Tension Ignition Cable or equivalent. This wire is very resistant to severe conditions of oil, heat, and corona, and is tested to withstand high voltages up to 25,000V rms in a salt bath for one minute without breakdown. It is rated at 200°F (93°C) for continuous duty, and up to 350°F (175°C) for intermittent use.

IMPORTANT: Do not run high voltage ignition transformer wires in the same conduit with the flame detector wiring.

5. Refer to Fig. 2 and 3 for typical field wiring connections. Follow the burner manufacturer’s wiring diagram if provided.

Fig. 2—Gas system with interrupted ignition.

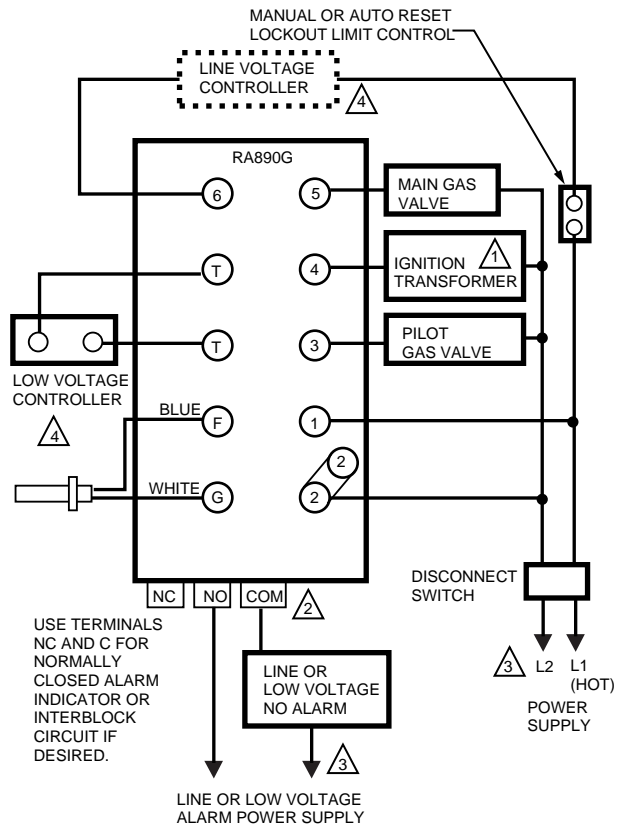

- △1 FOR INTERMITTENT IGNITION, CONNECT TO TERMINAL 3.
- △2 ALARM TERMINALS OPTIONAL. IF LINE VOLTAGE ALARM IS USED, RA890G MUST BE MOUNTED IN SUITABLE ENCLOSURE. ALARM TERMINALS ARE ENERGIZED THROUGH THE RA890 SAFETY SWITCH. ALARM IS NOT SOUNDED UNTIL THE SAFETY SWITCH TRIPS OUT.
- △3 PROVIDE DISCONNECT MEANS AND OVERLOAD PROTECTION AS REQUIRED.
- △4 MAY USE LINE OR LOW VOLTAGE CONTROLLER. IF LINE VOLTAGE CONTROLLER IS USED, CONNECT IT BETWEEN THE LIMIT CONTROL AND TERMINAL 6. JUMPER T-T.

APPLICATIONS

Either a line or low voltage controller can be used. If a line voltage controller is used, connect it between the limit control and terminal 6, and jumper T-T.

Refer to the appropriate flame detector instructions when paralleling two flame detectors.

IMPORTANT: The C7027, C7035 and C7044 Flame Detector leads are color coded blue and white. The blue lead must be connected to the F terminal and the white lead to the G terminal. The circuit is dc and the UV tube is polarity sensitive. Reversing the leads, even momentarily, can damage or destroy the UV tube.

All wiring must be NEC Class 1 and conform to local electrical codes, ordinances, and regulations. If the leadwires are not long enough to reach the flame safeguard control, splices must be made in a junction box.

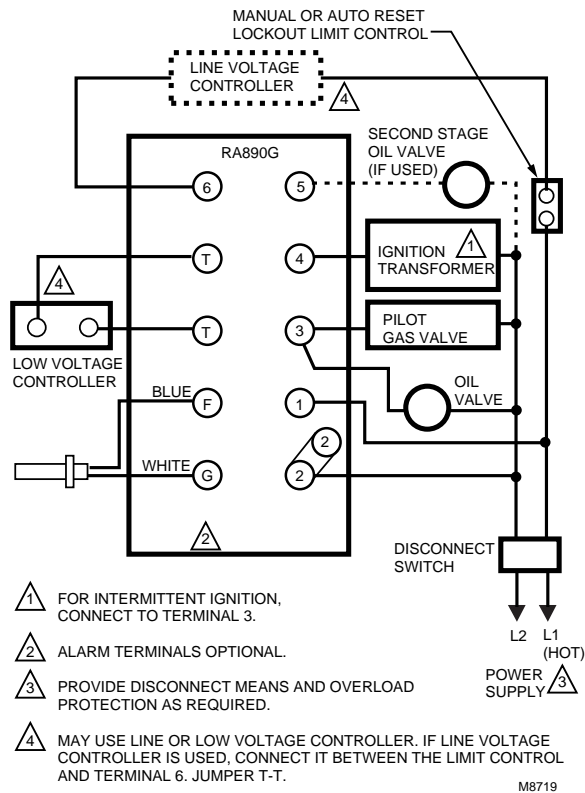
Fig. 3—Oil-Fired system with interrupted ignition.

The use of manual reset limits is desirable with the RA890G to prevent the system from cycling off the high limit and to assure that the condition that causes the limitation is detected as soon as possible.

MOUNT RA890G

Check that the power is Off.

Remove relay cover and position the RA890G over the Q270A Universal Mounting Base. See Fig. 4. Start all ten mounting screws and tighten uniformly. These screws complete electrical circuits and hold the RA890G to the subbase.

As shipped from the factory, the RA890G is suitable for use with interrupted or intermittent systems.

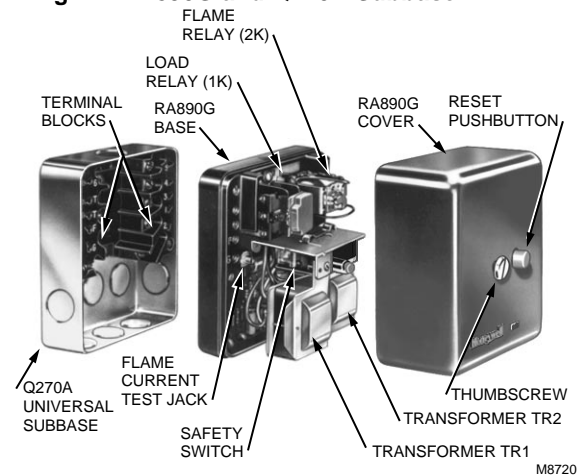
Fig. 4—RA890G and Q270A Subbase.

CAUTION

1. Use extreme care while testing the RA890G; line voltage is present on some terminals and contacts when power is On.
2. Disconnect power supply before removing cover, removing RA890G from subbase, or reinstalling RA890G onto subbase.

PRELIMINARY CHECKS

Before placing the system in operation, complete the following preliminary checks:

1. Check wiring. Use a meter to check the continuity of all circuits.
2. Check flame detector installation.
3. Check burner adjustments.
4. Thoroughly purge gas piping.
5. Reset the safety switch by pushing in and then releasing the purple safety switch button.

NORMAL OPERATION SUMMARY

Refer to Fig. 5 for the internal schematic of the control.

1. *Call for heat*—Load relay pulls in after a slight delay (flame relay must be out), ignition starts, pilot valve or burner motor is powered. Safety switch heats. A safety shutdown occurs if a flame or flame simulating condition is detected at startup.

2. *Flame proved*—Flame relay pulls in, safety switch heater is de-energized, main valve is powered, ignition is cut off (if used for interrupted ignition).

3. *Call for heat satisfied*—Load relay drops out, fuel valves close, burner motor stops, and flame relay drops out.

NOTE: The pull-in of the load relay is delayed by a thermistor with a nominal delay time of 3 to 5 seconds. The thermistor is affected by ambient temperature. The delay time may be as little as two seconds when the ambient temperature is high, or as long as 30 seconds when the ambient temperature is low. As the thermistor warms up, the 1K relay may hum slightly before it pulls in. This is normal.

IMPORTANT: *If limit control opens, ignition and fuel valves are de-energized, but safety switch lockout will not occur. When normal conditions are restored and the limit closes, the RA890G recycles.*

CHECKOUT REQUIRED

Before the installation is complete, satisfactorily complete all checkout tests indicated below. Repeat these tests after any adjustments are made to the system.

Flame Current Check (all installations).

Pilot Turndown Test (all installations that required proof of pilot before main fuel valve is opened).

Ignition Spark Response Test (all installations).

Safe Shutdown Checks—Flame failure, power failure, limit action (all installations).

FLAME CURRENT CHECK

The Flame Current Check is the best indicator of proper flame detector application. Perform the check at the time of installation, at any time service is done on the system, and at

least once a month (or more often) while the system is in operation. This prevents shutdowns due to poor flame signal.

Use a W136A Microammeter, or equivalent, and read the flame signal while the burner is running. Insert a 196146 Test Cable, wired color-to-color to the W136A leadwires, into the test jack on the RA890G. See Fig. 6.

When reading the flame current, assure that the following criteria are met:

1. The flame current is steady; meter does not vary more than a needle width.
2. The flame current is at least 1.5 microamperes for an ultraviolet type detector such as used with the RA890G.

If a satisfactory reading is not obtained, check the power source for the proper line voltage, and the flame size and the detector for proper sensing.

Directions for obtaining a steady current reading are included in the instructions packed with the C7027, C7035 or C7044 Ultraviolet Flame Detector.

NOTE: Flame current cannot be measured by putting a microammeter in the F lead.

Fig. 5—Internal Schematic of RA890G (Typical External Connections Included).

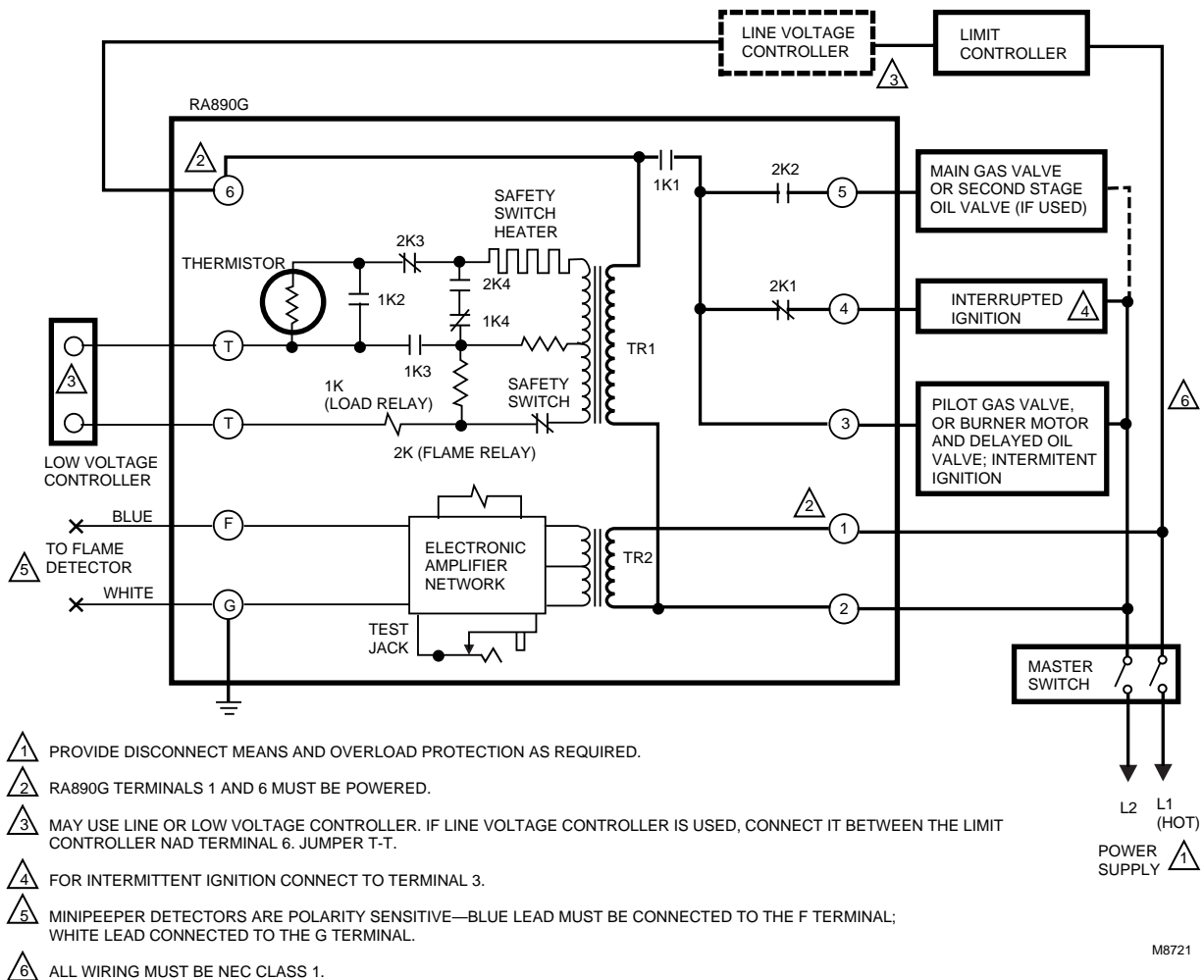
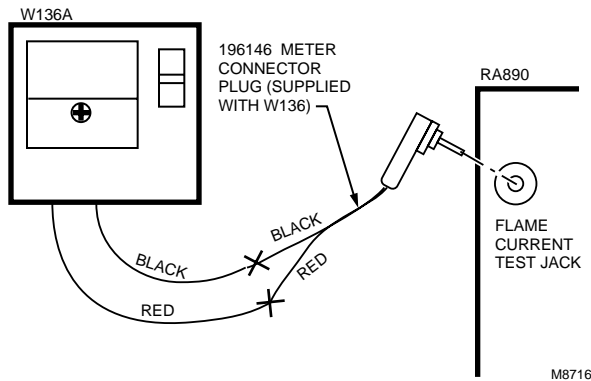

Fig. 6—Flame current check.



PILOT TURNDOWN TEST



CAUTION

The pilot turndown test should be performed only by qualified personnel, and the instructions should be followed carefully.

On systems that prove a pilot before the main fuel valve can be opened, perform a pilot turndown test to prove that the main burner can be lighted by the smallest pilot that will hold in the flame relay. Perform a flame current check before and after the pilot turndown test.

1. Open the main power switch.
2. Shut off the fuel supply to the main burner *only* by closing the manual main burner shutoff cock. *Do not shut off the fuel supply to the pilot valve.*
3. Restore power to the relay.
4. Start the system by raising the setpoint of the controller (or pressing the START button). The pilot will light and pull in the flame relay.
5. Reduce the size of the pilot flame to the turndown condition by slowly closing the manual valve on the pilot gas line. At the turndown condition, the pilot will be small enough to just barely hold in the flame relay (2K).
 - a. Turn down the pilot until relay 2K drops out.
 - b. Turn the pilot back up slowly just until relay 2K pulls back in.
 - c. Again turn the pilot down slightly, but not enough so the relay drops out.

If the relay drops out again, simply turn up the pilot and try again. The closer the pilot is to the dropout condition, the more conclusive the test will be.

6. Check that the pilot is lit and relay 2K is pulled in.
7. Open the manual main burner shutoff cock. Main flame should light smoothly within one second. *If the burner does not light within one second, close the shutoff cock and shut off power to the relay. Proceed to step 9.*
8. If the burner lights, repeat step 7 two or three times to verify smooth lightoff.
9. If the lightoff is unsatisfactory, readjust the flame detector to require a larger pilot flame to hold in the flame

relay. This usually requires resighting the detector farther out on the axis of the pilot flame.



CAUTION

If the pilot needs to be adjusted and rechecked, allow five minutes for the purge of unburned gases in the firebox before proceeding to the next step.

10. Repeat the entire turndown test until the flame is established promptly in step 7.

11. Turn up the pilot to full flame at the completion of the test. Perform a flame current check before leaving the job.

IGNITION SPARK RESPONSE TEST

The flame detection system should not respond to the ignition spark (no meter movement). To determine flame detector sensitivity to ignition spark, perform the following steps:

1. Shut off pilot and main fuel manual valves.
2. Connect a W136 Microammeter and 196146 Test Cable into the test jack on the RA890G. (See Flame Current check procedure section.)
3. Raise the controller setpoint. This should energize the ignition transformer and produce an ignition spark.
4. The W136 Meter should not indicate a signal present.
5. If the meter indicates UV is being detected, resight the flame detector until the UV signal is eliminated. It may be necessary to construct a barrier to block the ignition spark from the detector view. Continue adjusting until the ignition spark flame signal is less than one-fourth microampere.

NOTE: The Honeywell Q624A Solid State Spark Generator prevents detection of ignition spark when properly applied with flame detection systems using C7027, C7035, or C7044 Minipeeper Ultraviolet Flame Detectors. The Q624A is for use only with gas pilots.

SAFE SHUTDOWN CHECKS LIMIT ACTION

With the burner operating, lower the high limit setting to simulate an overheated boiler or furnace. Normal shutdown should occur. Restore the normal limit setting; the burner should restart.

FLAME FAILURE RESPONSE TEST

With the burner operating for a period of five minutes, close the manual fuel valves to simulate a flame failure. The W136 Meter reading should drop to zero within the flame response timing of the flame safeguard relay (0.8 to 3 seconds nominal). This action should be followed by safety switch lockout (15 seconds nominal). After the safety switch cools, open the manual valves. The burner should restart when the safety switch is reset.

If the meter reading does not drop to zero within the allowed time, replace the UV detector and repeat the test.

IMPORTANT: Repeat ALL required checkout tests after all adjustments are complete. ALL tests must be satisfied with the flame detector in its FINAL position.

POWER FAILURE

With the burner operating, open and then immediately close the line switch to simulate a power failure. Burner should shut down. After a short delay for component check, burner should restart and operate normally.

FLAME DURING START

The RA90G should shut down on safety during start-up if a flame or flame simulating condition is detected. Insert 123514B flame simulator into the test jack. Start the system by raising the controller setpoint or pressing the start button.

Hold the simulator on terminal F; the flame relay should pull in and system should lock out within the safety switch timing. Remove the simulator and reset the safety switch after it cools.

NOTE: At the completion of all Checkout tests, make sure that the RA890 is not on safety lockout, the pilot is turned up to its normal level, and all limit settings are correct. Operate the system through one normal cycle before leaving the installation.

Service



CAUTION

1. Only a trained, experienced, flame safeguard control technician should attempt to service or repair heating equipment or controls.
2. Under certain conditions, a capacitor between terminals F and G within RA890G can remain charged even after the power is disconnected and the device is removed from the mounting base. TO AVOID THE HAZARD OF ELECTRICAL SHOCK, ALWAYS USE A SCREWDRIVER WITH AN INSULATED HANDLE AND AVOID TOUCHING THE F AND G TERMINALS.
3. Never manually push in the RA890 Relays.

GENERAL

1. Repeat all checks required in the Checkout section when replacing any system component, or when relighting or restoring power to the system after an extended shutdown period.
2. The captive mounting screws carry current; *always disconnect power before loosening or tightening the mounting screws.*
3. On each service call, check the controller for the approximately correct calibration and differential; assure that it is mounted securely (see controller instructions).
4. Never use oil on any part of the RA890G.
5. When cleaning the burner, clean the flame detector lens.
6. **DO NOT MANUALLY PUSH IN THE RA890 RELAYS.** This may damage the relays and it is an unsafe practice because it overrides the protective features of the relay. Clean relay contacts only as instructed below.

PERIODIC MAINTENANCE

The specific maintenance schedule setup depends on several factors including type of equipment being controlled, operating conditions (dirt and heat especially), cost of a nuisance shutdown, etc. Include the following in any maintenance program:

1. Perform a Flame Failure Check and Pilot Turndown Test whenever the burner is serviced, and at least annually.

2. Inspect and clean the detector and any viewing windows as often as required by soot accumulation and heat conditions at the detector.
3. Perform a Flame Current Check at least monthly, and more often when a shutdown may be costly.
4. Clean contacts only when required by failure to operate properly.

CONTACT CLEANING

CAUTION

Open the master switch before removing the relay over or before cleaning contacts. Line voltage may be present on most contacts when power is on.

Field cleaning of relay or timer contacts is not recommended. If they must be cleaned, use *only* Honeywell pressurized Contact Cleaner part no. 132569. Honeywell's chemical analysis laboratory recommends only this cleaner. Directions for using the cleaner are printed on the can.

IMPORTANT:

1. *Do not clean contacts unless absolutely necessary.*
2. *Use only Honeywell Contact Cleaner part no. 132569. Do not use any other type of contact cleaner.*
3. *Use extreme care to avoid bending the contacts or changing the specifications or configuration in any way.*
4. *Do not use abrasive material to clean contacts.*
5. *Do not use hard paper such as a business card to clean the contacts.*

Do not use other types of contact cleaners. Honeywell's chemical analysis laboratory tested other pressurized type contact cleaners but did not approve them for these reasons:

1. The solvents could deteriorate plastic parts and wire insulation.
2. The cleaners have an oily residue that collects dust and dirt. The residue breaks down to form various carbonaceous products. Either result causes early contact failure.

Do not use an abrasive (burnishing tool, sandpaper, stick, file, etc.) to clean contacts because it can cause early contact failure for these reasons:

1. Some relay and time contacts are plated with gold for increased reliability. Burnishing can quickly remove the plating.

2. The radii or points of the contacts are designed with specific shapes to best serve the intended functions of the contacts. Burnishing can rapidly alter contact configurations.

3. Using an abrasive loosens fine particles of the contact material that adhere to the surface of the contact and increase its resistance.

4. Contact specifications (contact pressures, pressback, and gaps) are carefully controlled during manufacturing to assure maximum contact life. Burnishing can easily change these specifications.

Troubleshooting



CAUTION

1. Use extreme care while troubleshooting the RA890G; line voltage is present on some terminals and contacts when power is on.
2. Disconnect the power supply before removing the cover, cleaning contacts, removing the RA890G from the subbase, or reinstalling the RA890G on the subbase.

When trouble occurs in the heating system and its cause is not immediately apparent, the serviceman can apply the following step-by-step checkout to locate the cause of most problems.

TEST STANDBY OPERATION

1. Set controller not to call for heat (decrease setpoint).
2. Reset the safety switch by pushing in and then releasing the purple safety switch reset button.
3. Close the line switch.
4. Check for line voltage between terminals 6 and 2, and between 1 and 2. (Voltage will be zero at terminal 6 if a line voltage controller is used; check for line voltage when controller is set to call for heat.)
 - a. Voltage must be within +10 to -15 percent of the rated voltage.
 - b. If voltage is zero, check the power supply line for blown fuses, open circuit, or open disconnect switch. Check limit contacts for continuity.
5. Check position of flame relay. (If a line voltage controller is used, observe the action of the flame relay on a call for heat.)
 - a. If the flame relay is out, proceed to step 6.
 - b. If the flame relay is pulled in, check for a flame simulating condition.
 - 1) Insert 123514B Flame Simulator Plug into test jack; touch the other end to the F terminal of the RA890G.
 - 2) If flame relay holds in, replace the RA890.
 - 3) If flame relay drops out, trouble is in the flame detector or external circuit. Replace the detector.

TEST STARTING OPERATION

6. Set controller to call for heat (increase setpoint).
7. Observe load relay for pull-in.
 - a. Load relay pulls in to light pilot and start burner; proceed to step 11.
 - b. Load relay does not pull in; proceed to step 8.

c. Load relay pulls in but does not light or burner does not start; proceed to step 10.

8. Check line voltage controller, if used, and check the limit; if the load relay does not pull in, check again for power at terminal 6 with the controller calling for heat. If there is power at terminal 6 and a line voltage controller is used, clean all relay contacts. Replace the RA890 if the relay still does not pull in. If a low voltage controller is used, proceed to step 9.

9. Check the low voltage controller, if used, by jumping T-T.

- a. Load relay pulls in with T-T jumpered; check controller and external circuit.
 - b. Load relay does not pull in with T-T jumpered; clean all relay contacts. Replace the RA890 if the load relay still does not pull in.
10. If the load relay pulls in but the pilot will not light or the burner will not start, check voltage at terminals 3-2 or 4-2.
- a. If no voltage at terminals 3-2 or 4-2; clean the relay contacts. Replace the RA890 if trouble cannot be corrected.
 - b. If normal line voltage at terminals 3-2 or 4-2, check external burner, ignition, and valve circuits. Check wiring, burner adjustment, ignition systems including electrode spacing and location, oil quality, character and efficiency of oil atomization, fuel supply pressure, flame pattern, flame character and quality, pilot location with respect to main burner, flame detector, or other conditions that may delay lightoff.

TESTING FLAME DETECTING FUNCTION

11. Observe the flame relay (right relay) for pull-in when flame is established.
 - a. Flame relay pulls in; proceed to step 13.
 - b. Flame relay does not pull in; proceed to step 12.
12. Check the flame relay with a 123514B Flame Simulator, if available (follow the instructions with the simulator), or check the following:
 - a. Perform a Flame Current Check (see Flame Current Check section).
 - b. If the current is satisfactory, replace the RA890.
 - c. If the current is not satisfactory, consult the instructions packed with the flame detector.

OBSERVE SEQUENCING OPERATION

13. Observe the second stage oil valve or main gas valve for opening when flame relay pulls in.
 - a. If valve does not open, check for line voltage at terminals 2-5.

- 1) Normal voltage—check valve and valve circuit.
- 2) Zero voltage—clean relay contacts. Replace the RA890 if this does not correct problem.
14. Observe ignition for cutoff when flame relay pulls in if connected to terminal 4.
 - a. If ignition stays on and wiring checks out, replace the RA890.

MISCELLANEOUS PROBLEMS

Relay Chatter

Load relay chatter may result from extreme low voltage (notify power company) or from a loose connection (tighten).

Flame relay chatter may result from improper combustion (adjust burner), or soot or carbon on flame detector (clean and correct the cause).

REPEATED LOCKOUTS OR CONTROL FAILURES

The most common causes of repeated failure of this control or flame detector or of repeated lockouts are:

- a. High ambient temperatures—over 125°F (52°C).
- b. Supply voltage variation greater than +10 to -15 percent.
- c. Electrical overloading of the contacts.
- d. Marginal flame current.
- e. Frequent cycling with high ambient temperatures.

Honeywell

Home and Building Control

Honeywell Inc.
1985 Douglas Drive North
Golden Valley, MN 55422

Home and Building Control

Honeywell Limited—Honeywell Limitée
740 Ellesmere Road
Scarborough, Ontario
M1P 2V9

Helping You Control Your World

QUALITY IS KEY

Printed in U.S.A.